

Spleiss/Patch Lösung // Splice/Patch solution

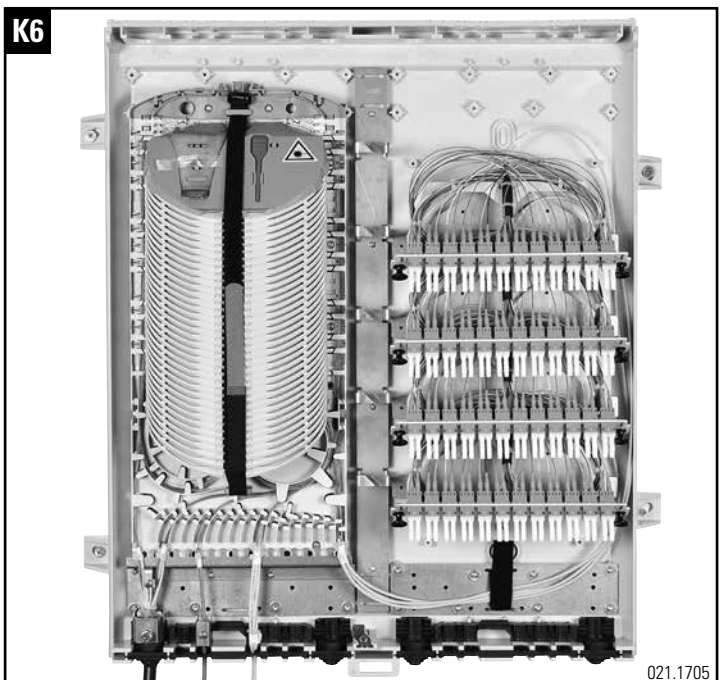

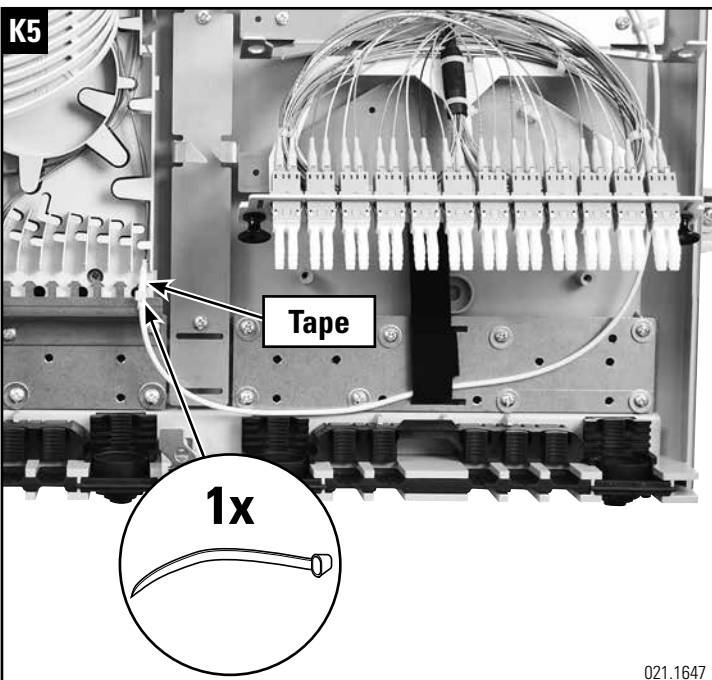

**K13**

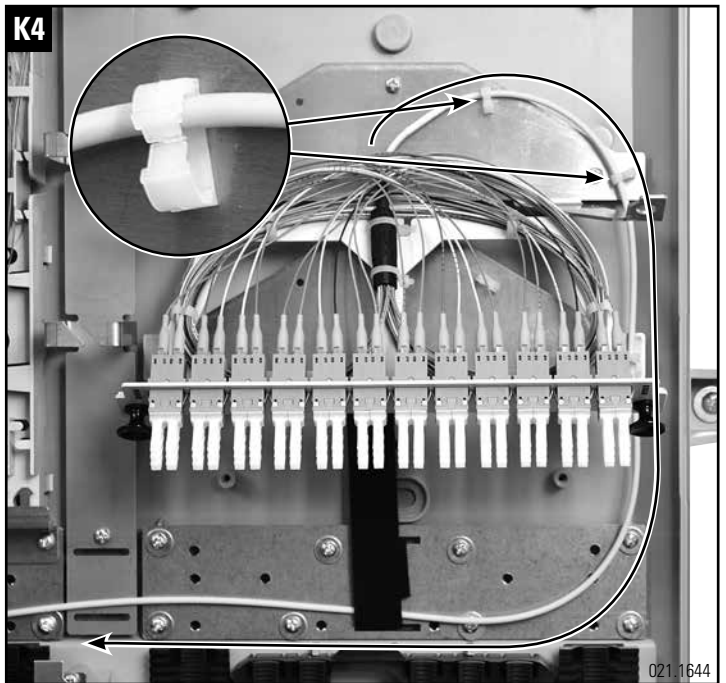
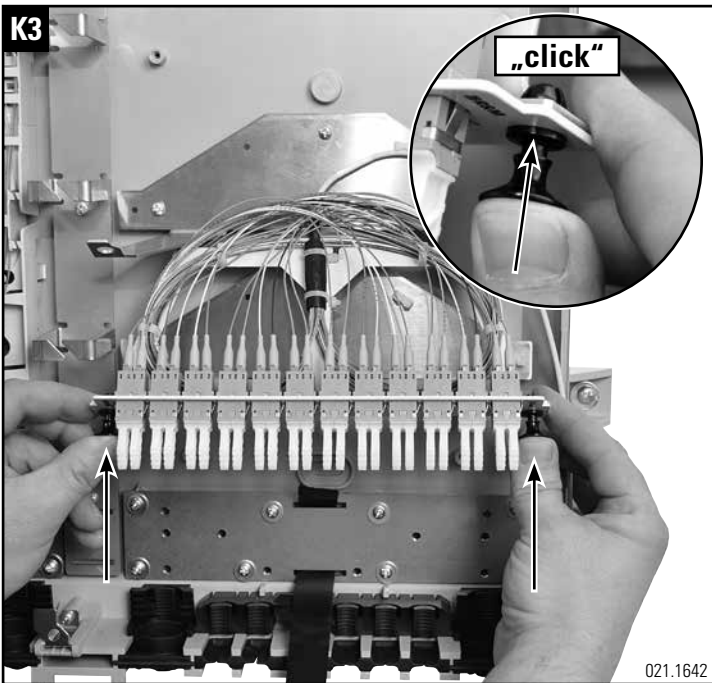
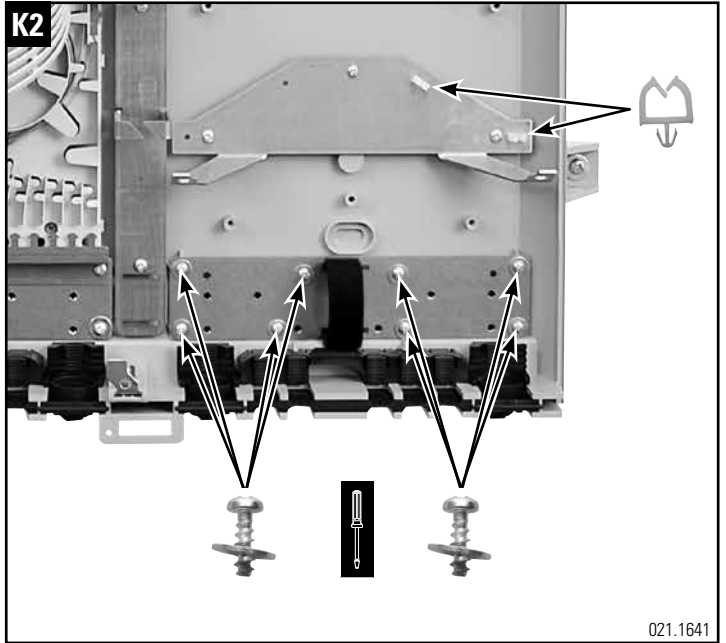
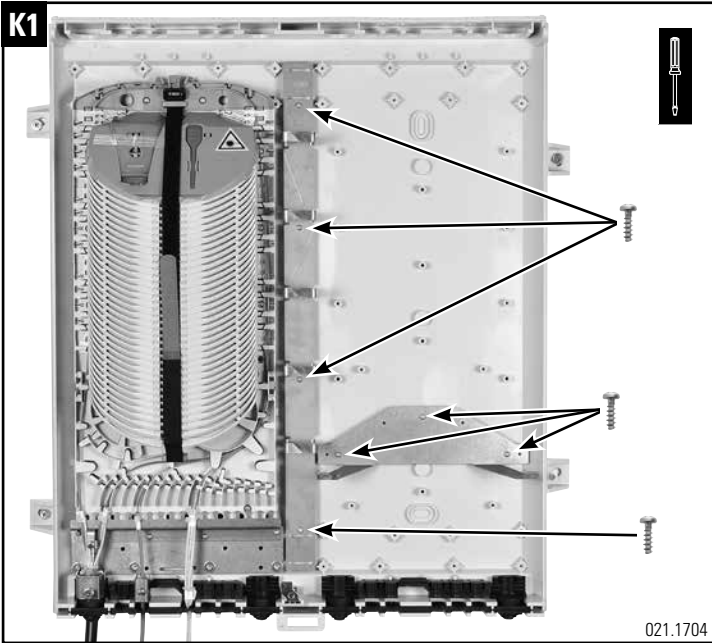
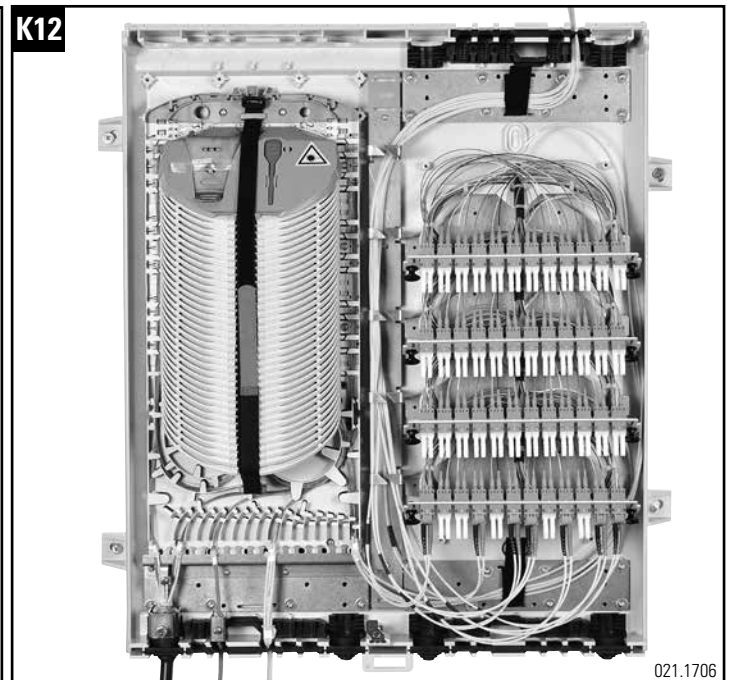
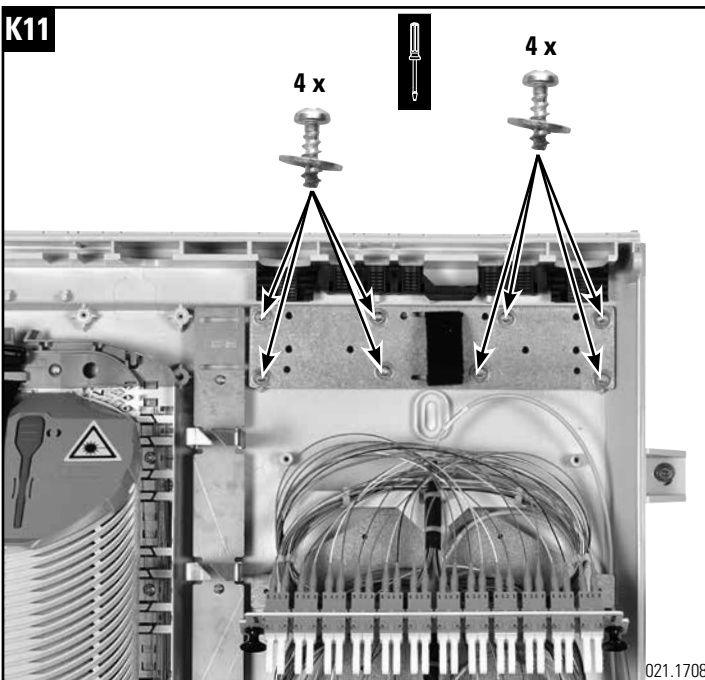
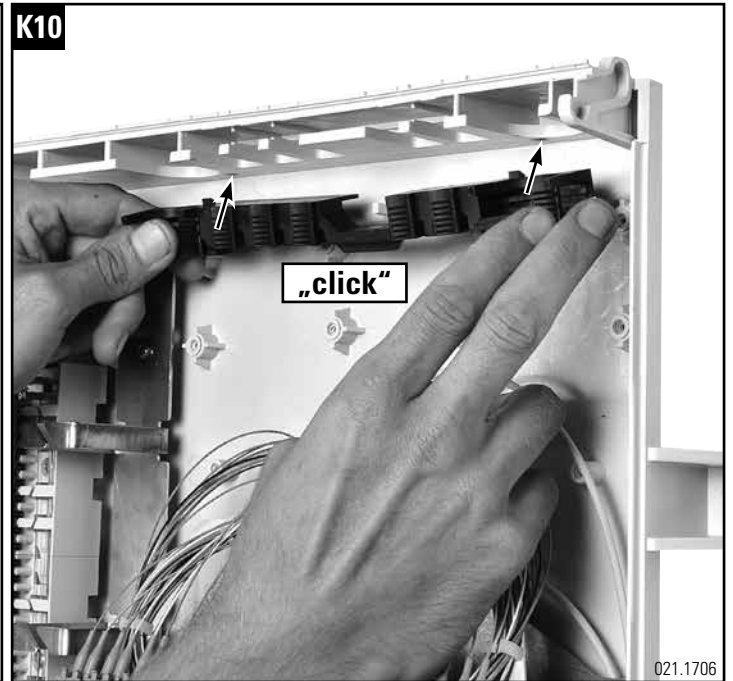
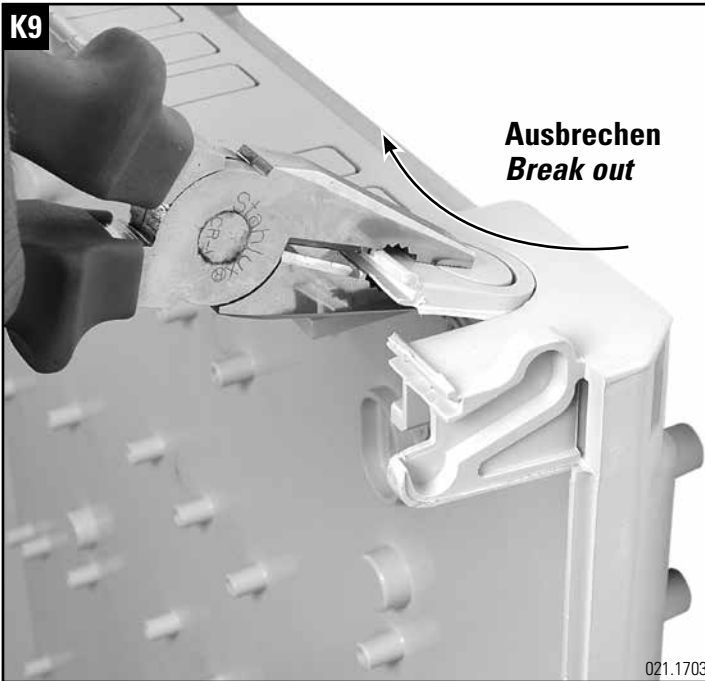
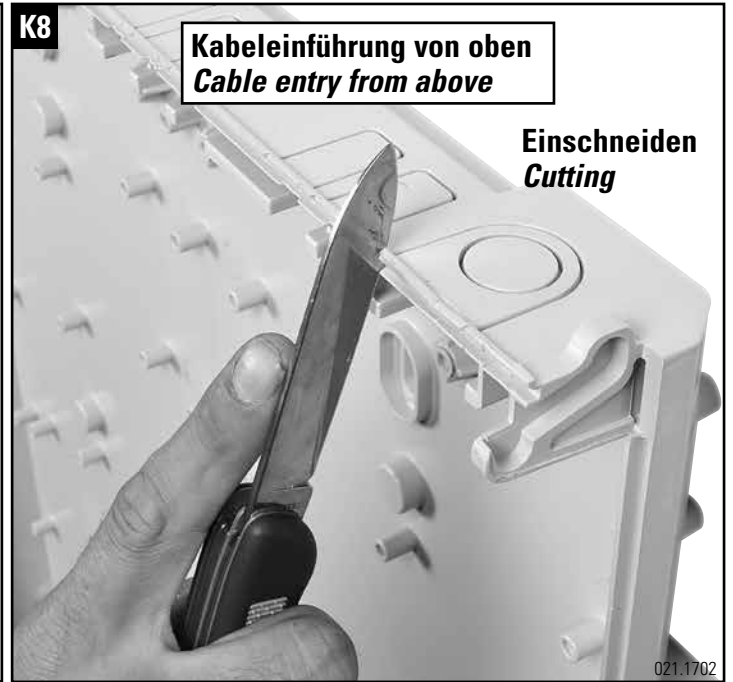
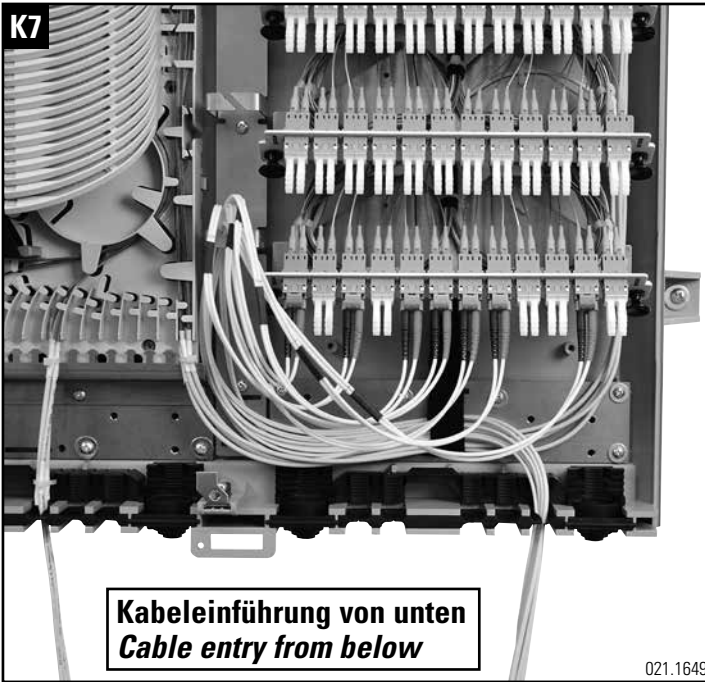
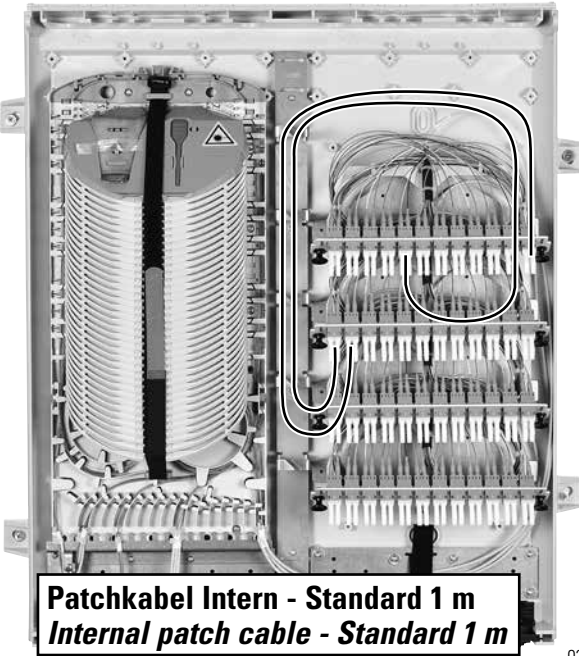

**Patchkabel Intern - Standard 1 m**  
*Internal patch cable - Standard 1 m*

021.1705

**Splitter Lösung / Splitter solution**

**L1**

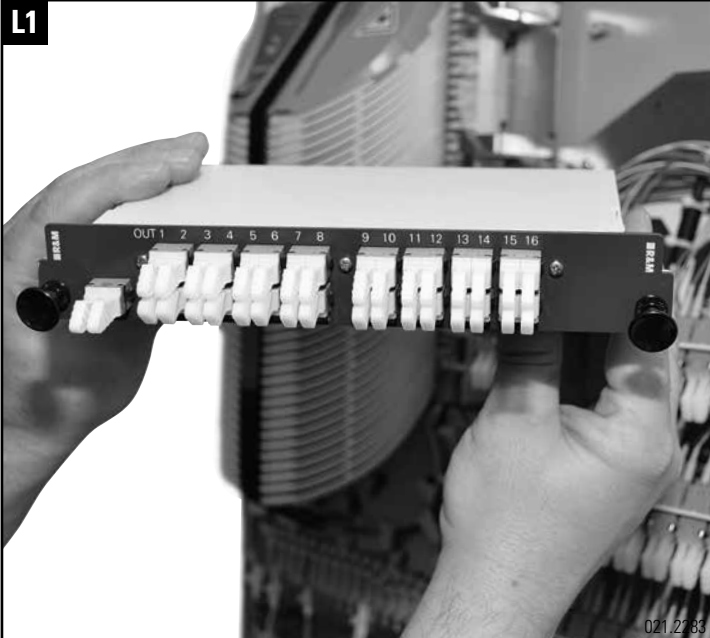

021.2283

**Patch Einschübe / Patch insert**

**M1**

**Max. 4 x 1HE/1U**



**12 x E-2000™ Compact**



**12 x LC Duplex**



**24 x LC Duplex**



**12 x SCRJ**



**24 x SC-Simplex**

021.1668 / 021.1669 / 021.1670 / 021.1671 / 021.1672

**L2**

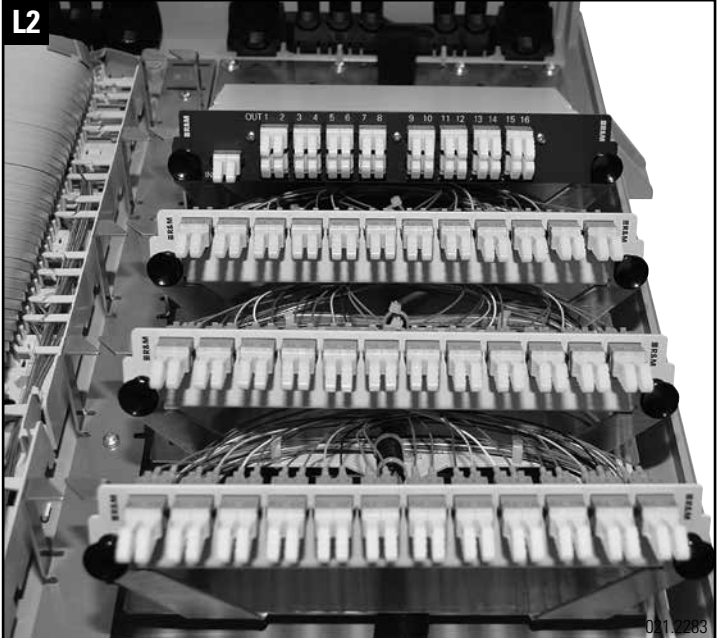

021.2283

**Splitter & CWDM Einschübe / Splitter & CWDM insert**

**M2**

**Max. 2 x 1HE/1U**

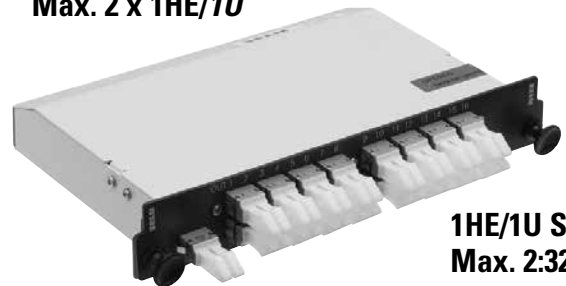

**1HE/1U Splitter**  
**Max. 2:32**



**1HE/1U CWDM**  
**Max. 16 Kanal/Channel**

090.6662 / 090.6666

**Spleiss/Spleiss Lösung und Einführung von unten // Splice/Splice solution and cable entry from below**

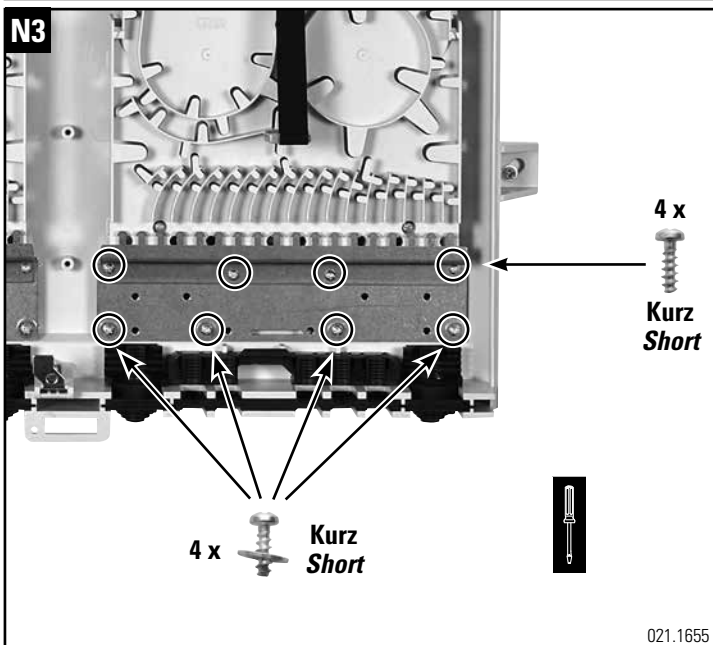
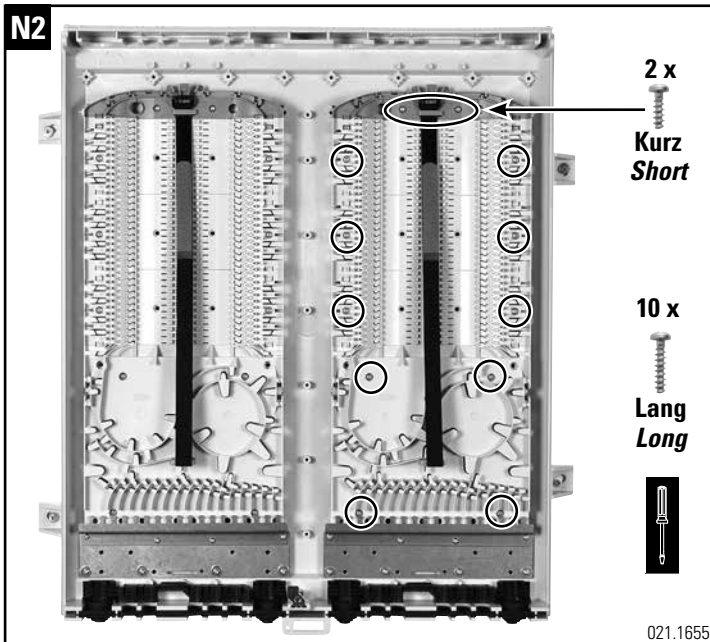
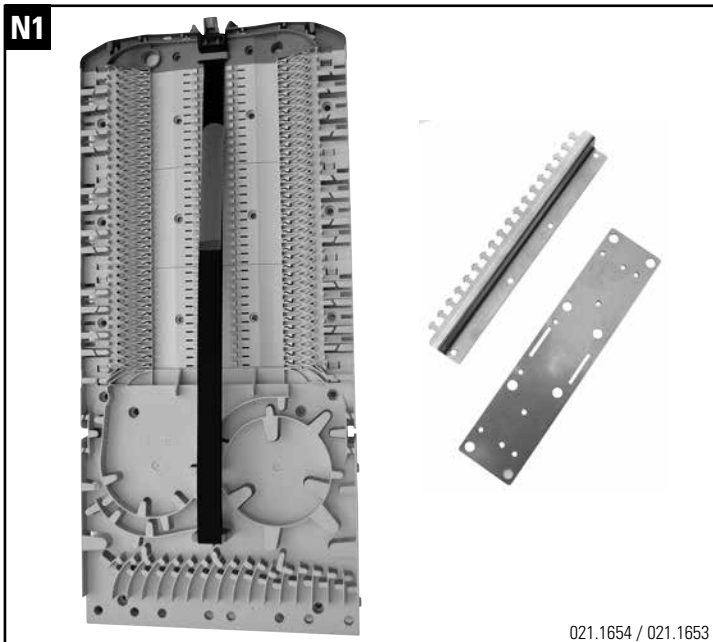

**Spleiss/Spleiss Lösung und Einführung von Oben // Splice/Splice solution and cable entry from above**

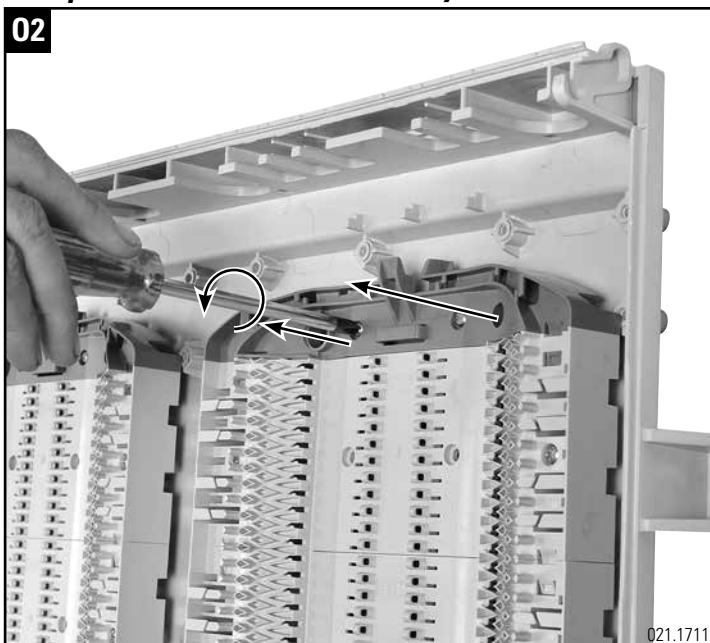
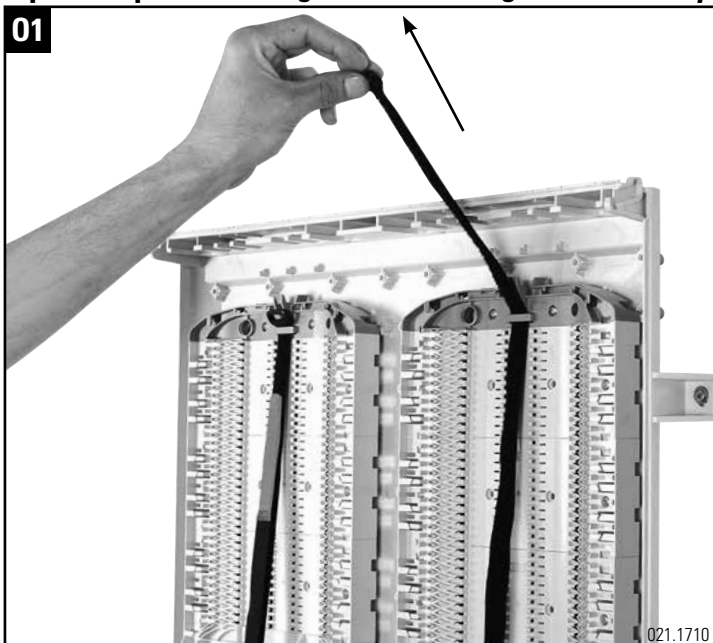

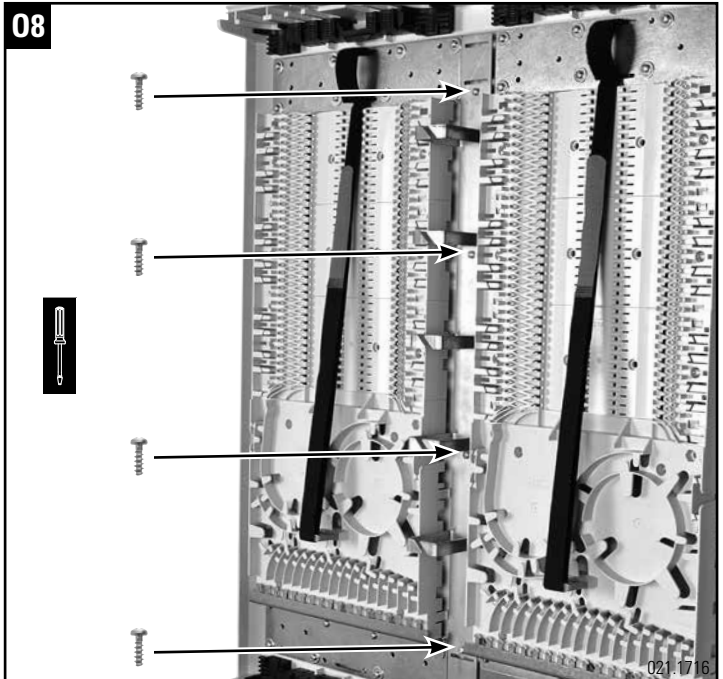
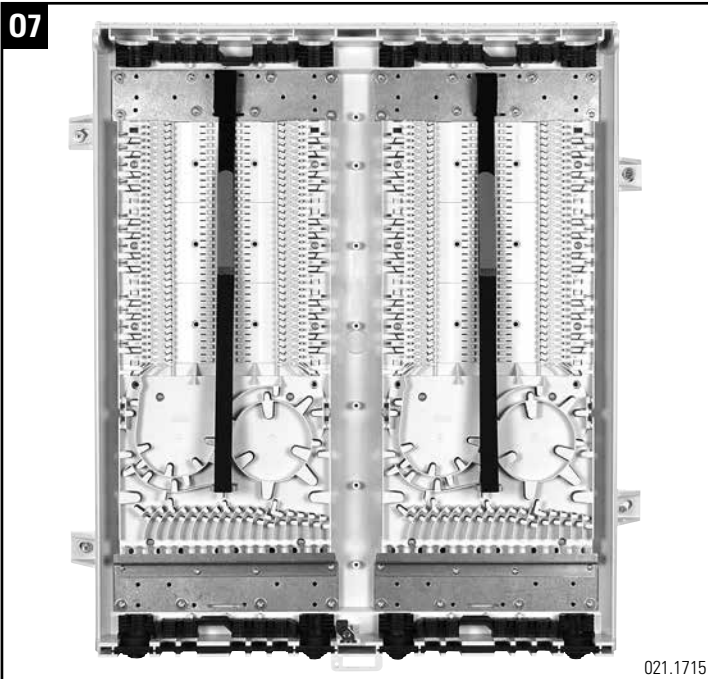
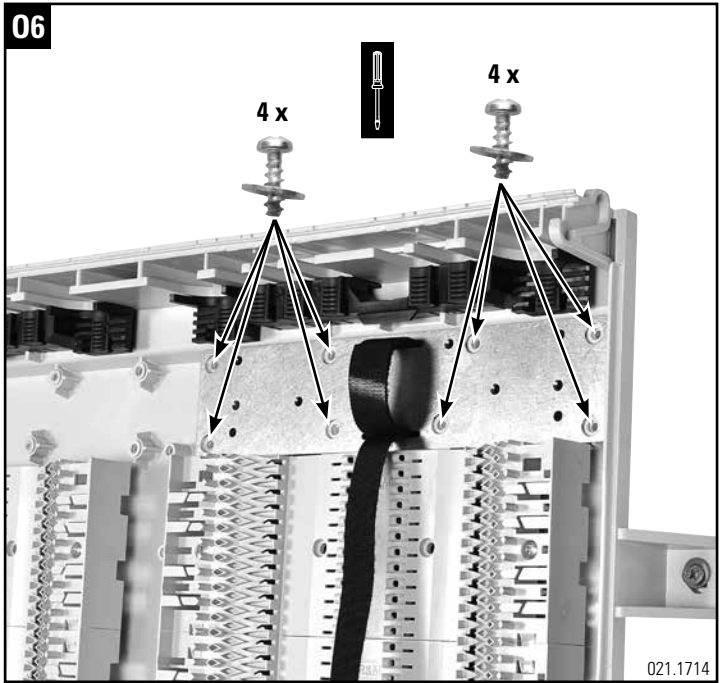
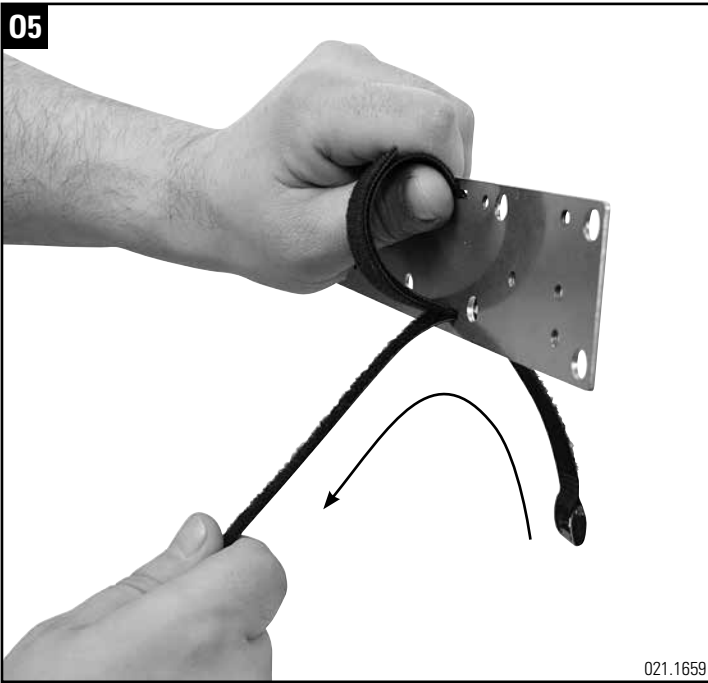
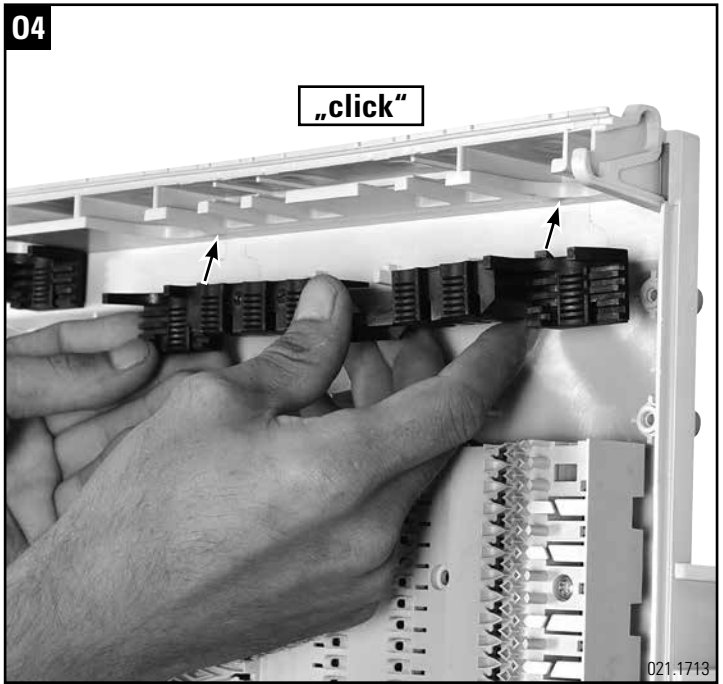
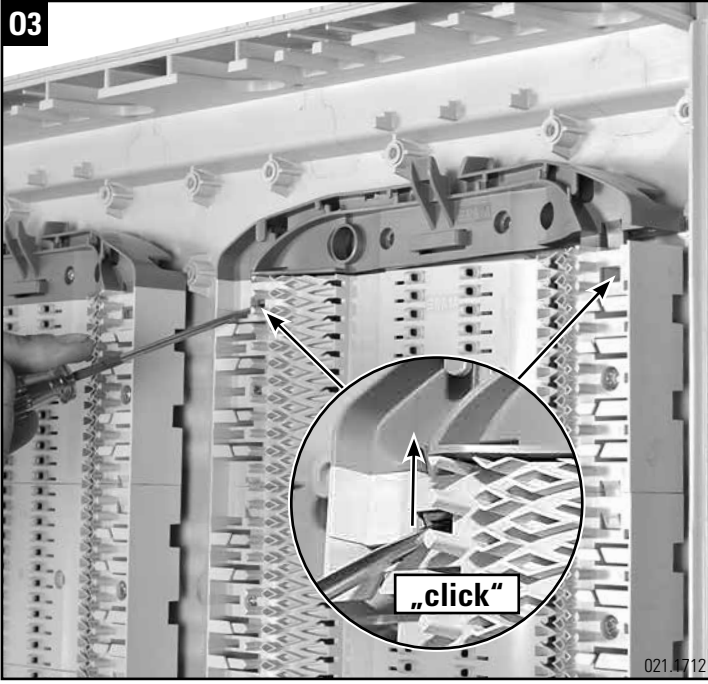

09

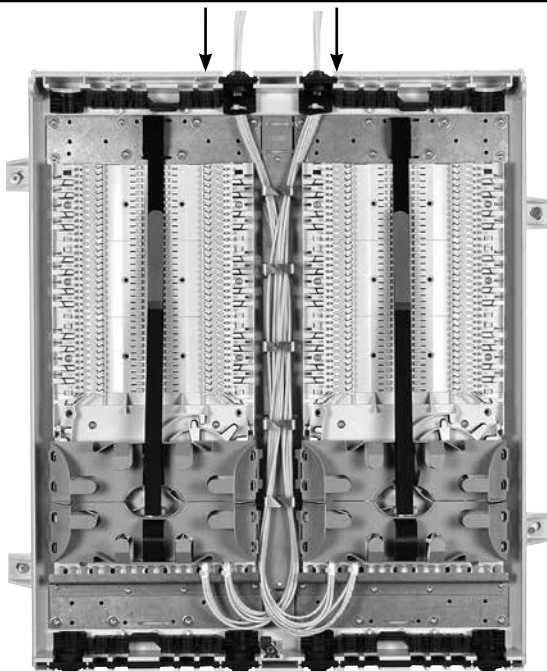

021.1717

**Max.**

- 72 x SC-Kassetten/trays
- 36 x SE-Kassetten/trays
- Bis zu 864 Fasern spleissbar  
Up to 864 fibers splicable

**Loop Option / Loop option**

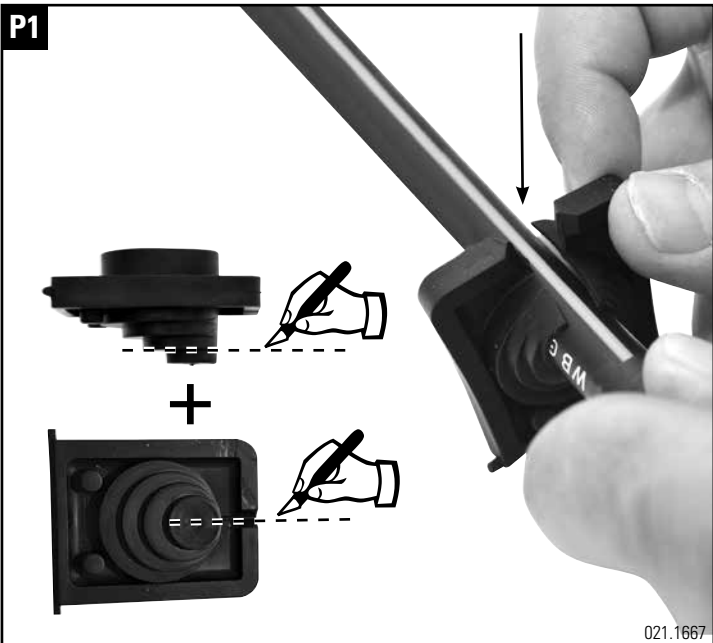

021.1667

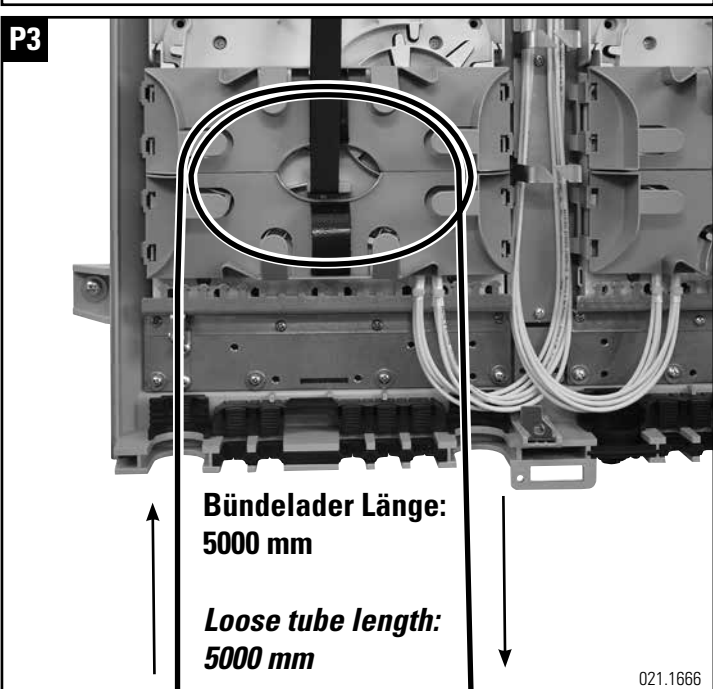
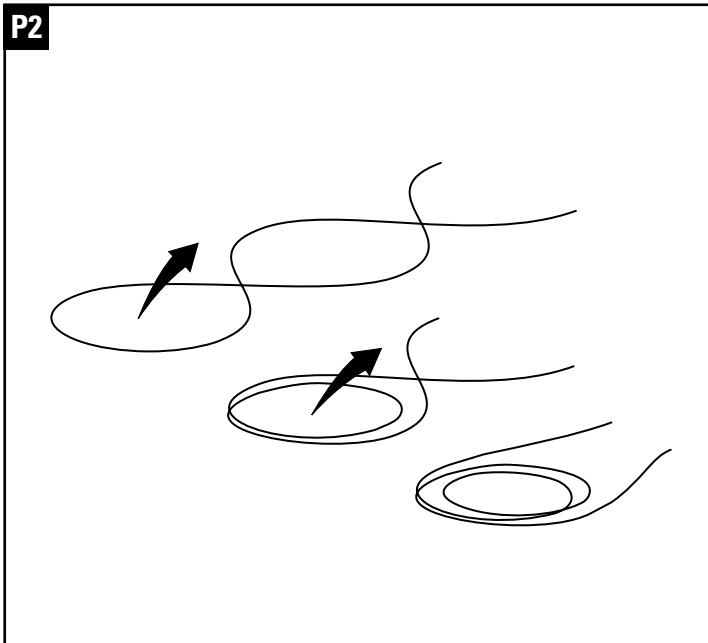

021.1666

# Mastbefestigung / Pole attachment

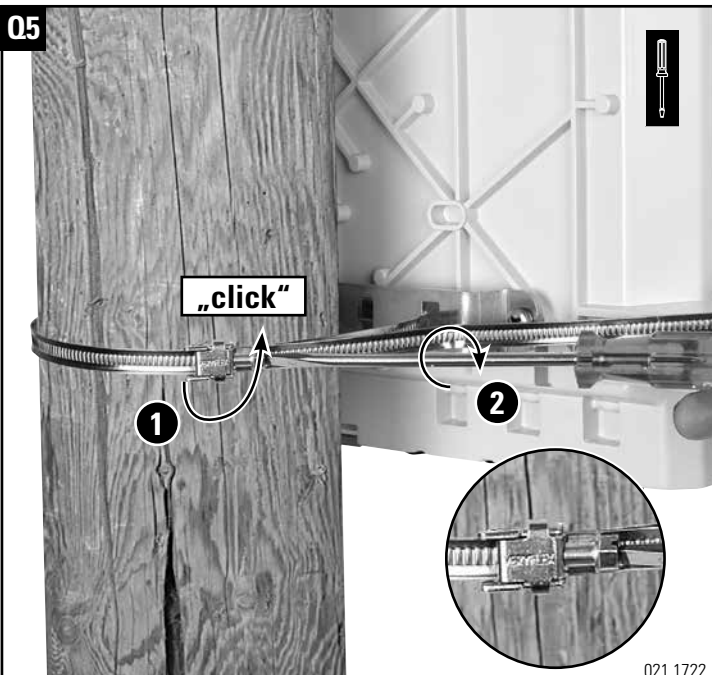
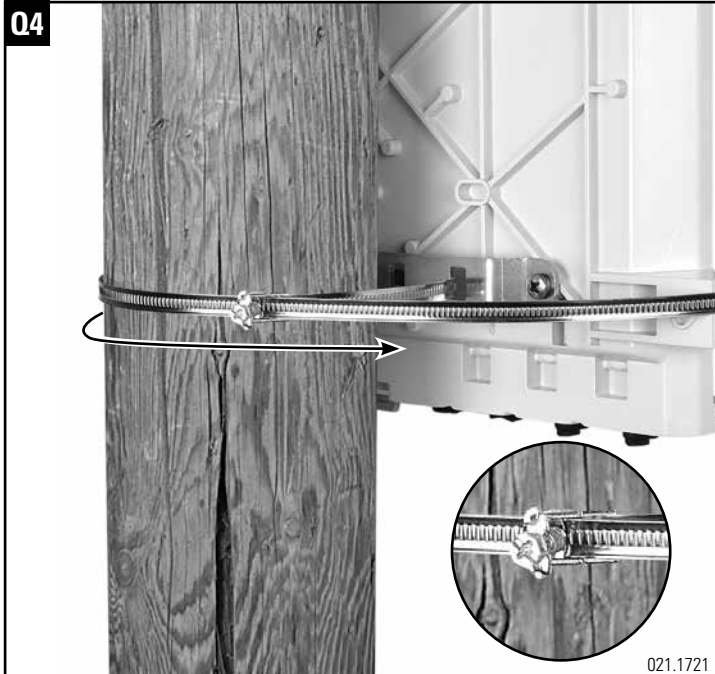
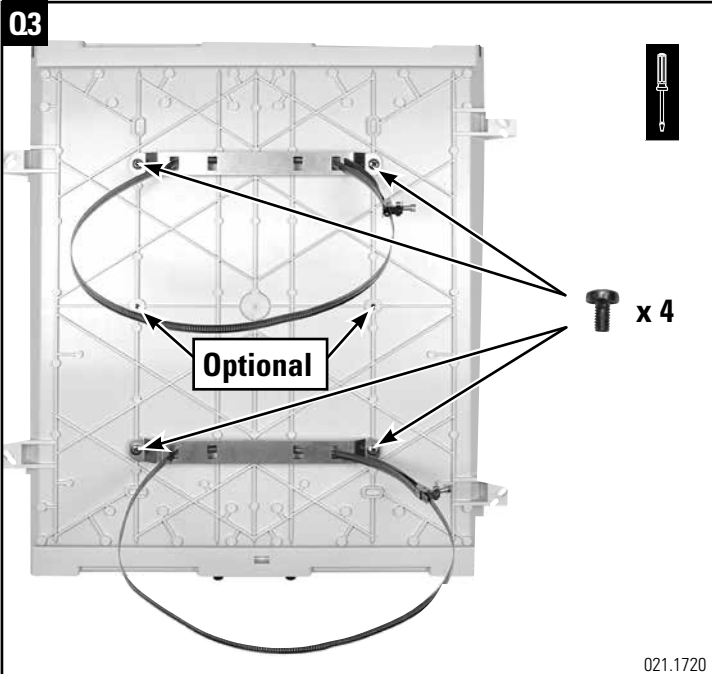
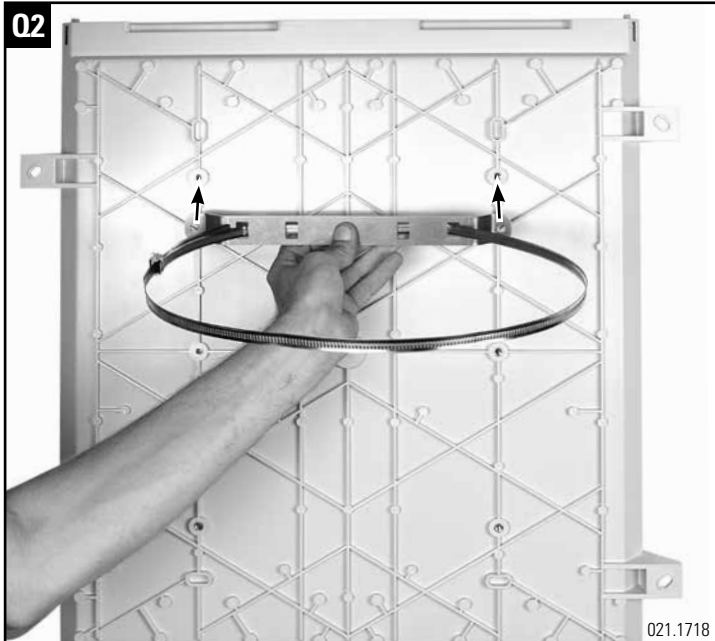
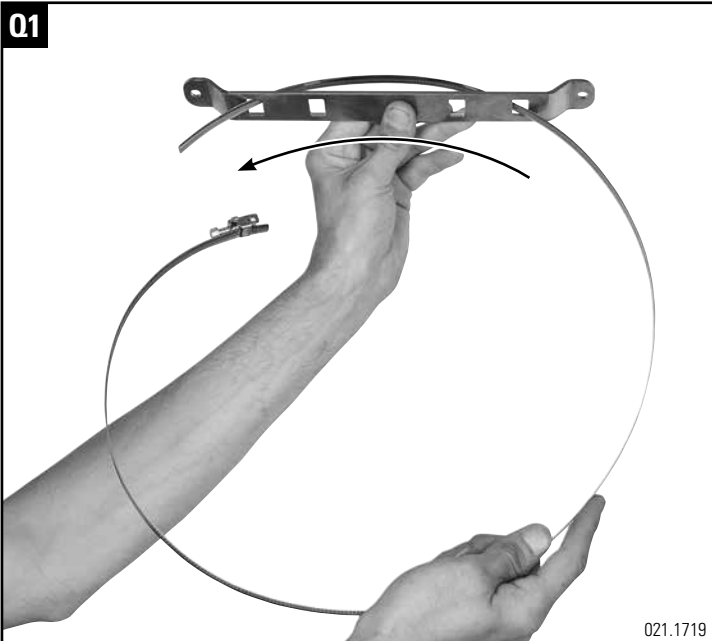

## Headquarters

### Switzerland

Reichle & De-Massari AG

Binzstrasse 32

CHE-8620 Wetzikon

Telephone HQ +41 (0)44 933 81 11

Telefax HQ +41 (0)44 930 49 41

E-Mail [hq@rdm.com](mailto:hq@rdm.com)

[www.rdm.com](http://www.rdm.com)

