

Installationsanleitung Venus FLA2-POL-PRE-32/16
Installation guide Venus FLA2-POL-PRE-32/16
Instructions de montage Venus FLA2-POL-PRE-32/16

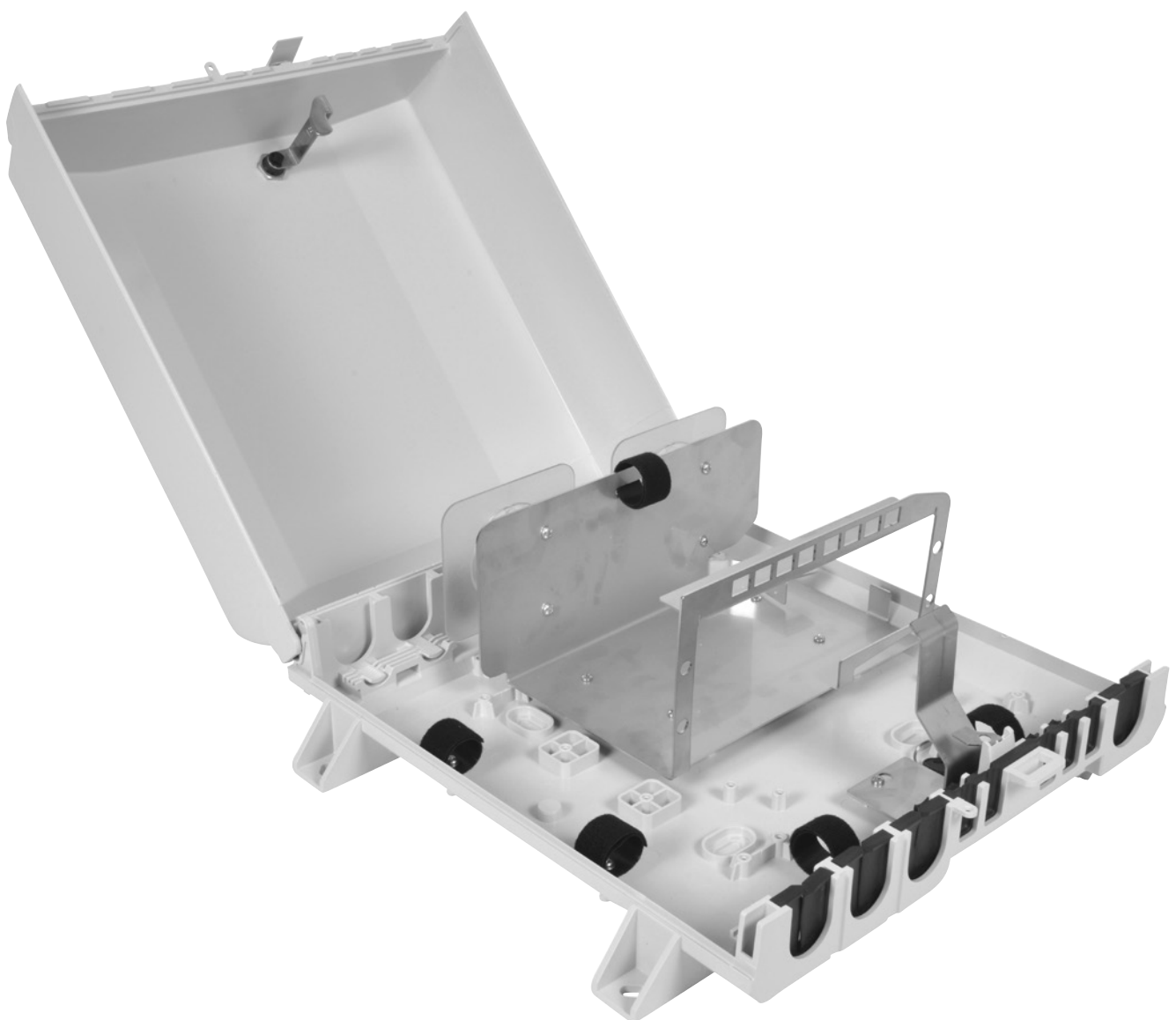

A - Preparation / Vorbereitung

A1 Mounting points / Montagepunkte



A2 Open / Öffnen

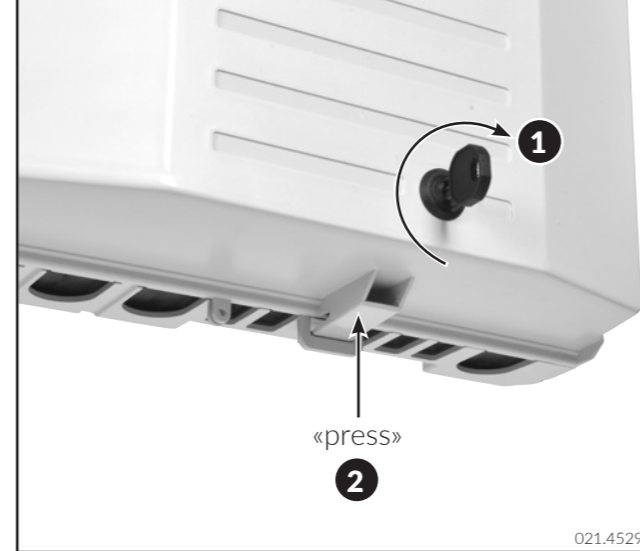

B - Insert splitter module / Splitter Modul einsetzen

B1 Splitter module 1:32 / 2:32

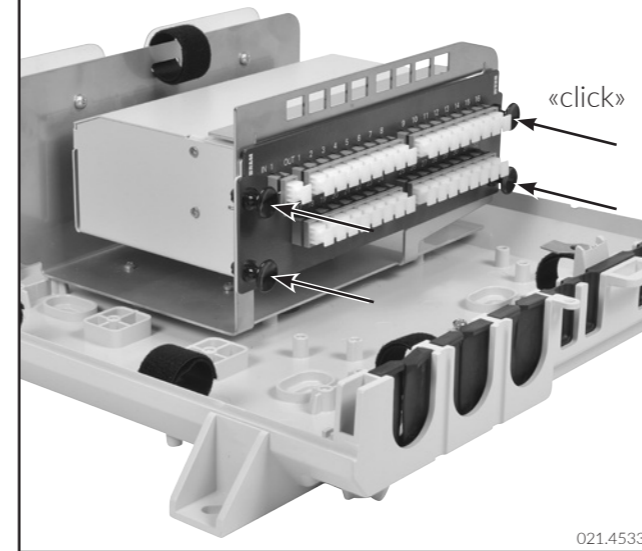

B1 Optional: Splitter module 1:16 / 2:16

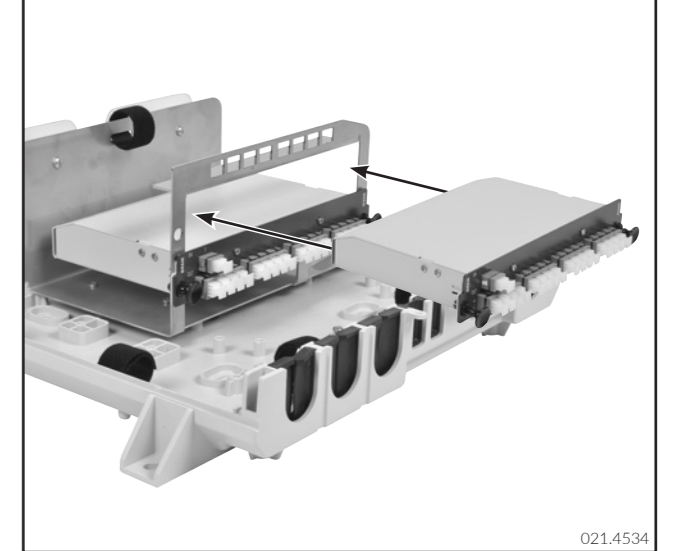

A3 Remove cover / Deckel entfernen

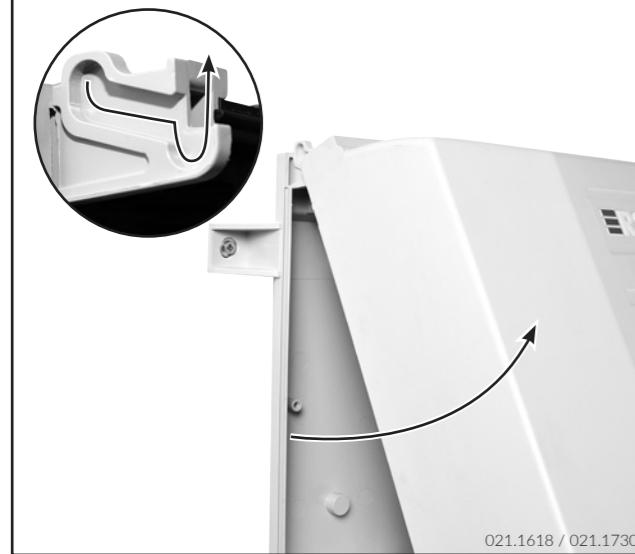

A4 Release bracket / Bügel lösen

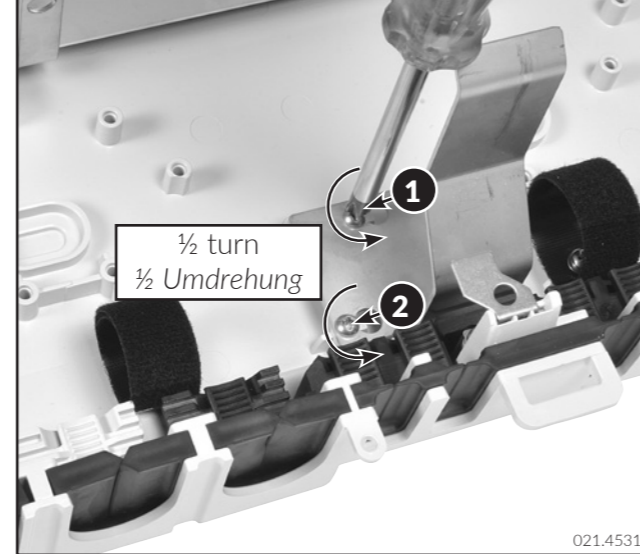

B3 Re-install bracket / Bügel wieder montieren



B4 Secure bracket / Bügel befestigt

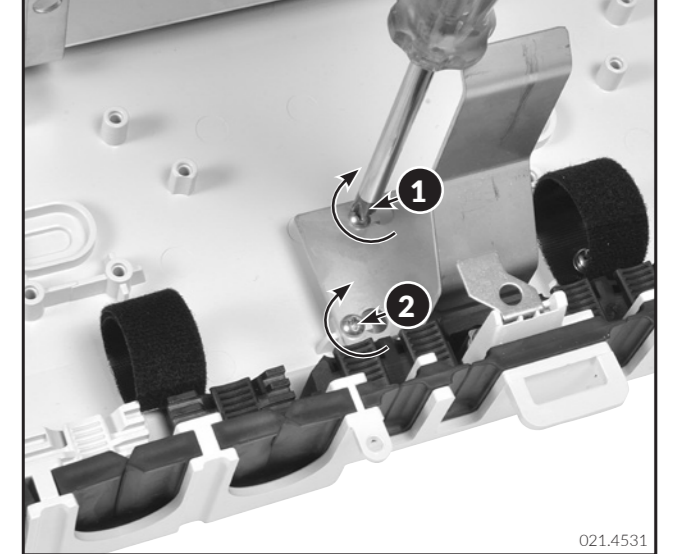

A5 Remove bracket / Bügel entfernen



C - Cable entry / Kabel Eingang

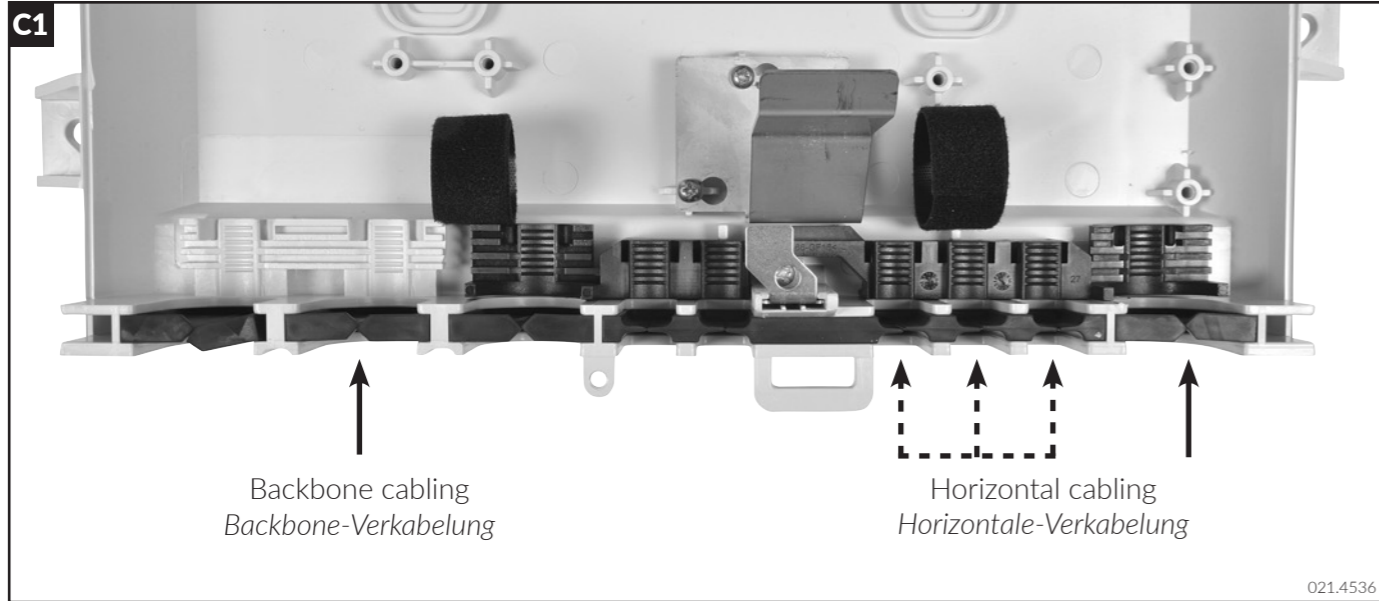

E - Backbone cabling - Pre-terminated cable / Backbone-Verkabelung - vorkonfektionierte Kabel

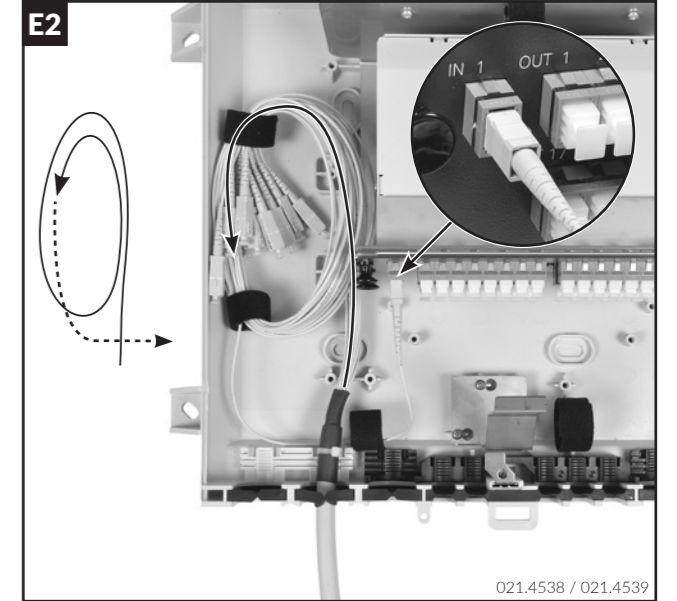
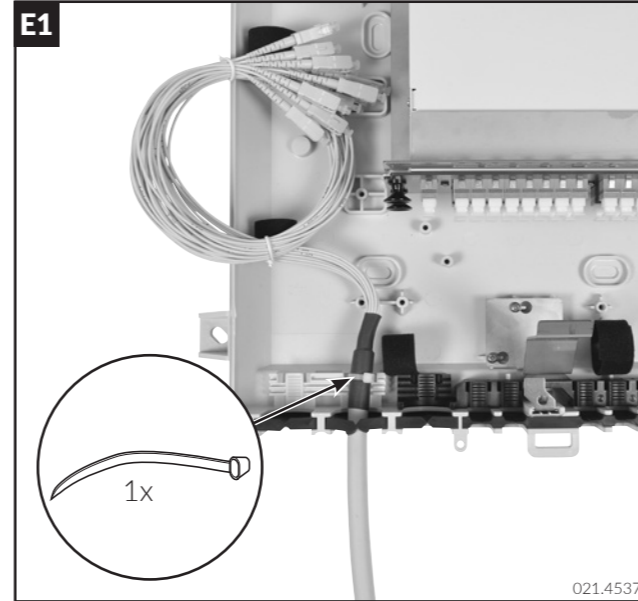

D - Backbone cabling - Mini Breakout / Backbone-Verkabelung - Mini Breakout

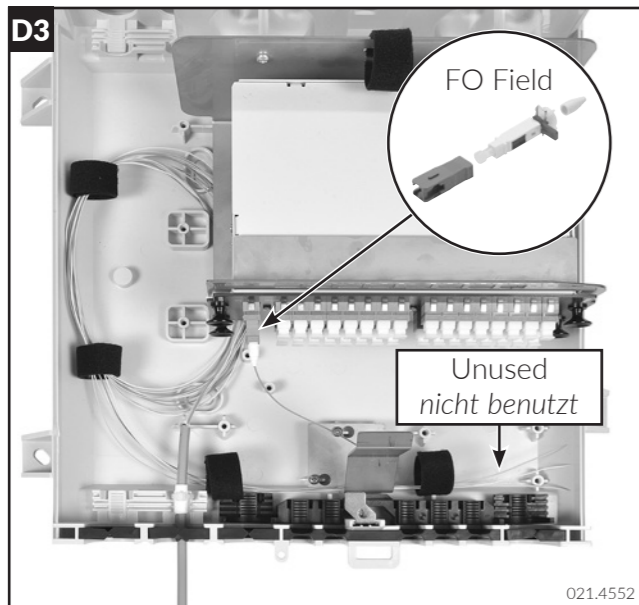
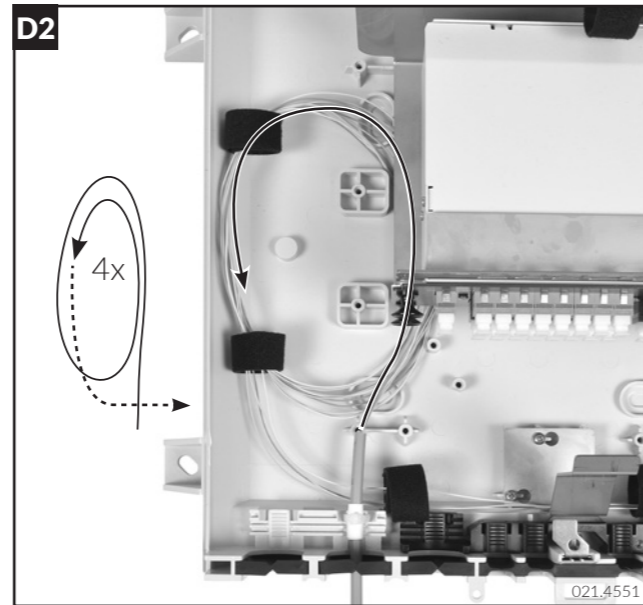
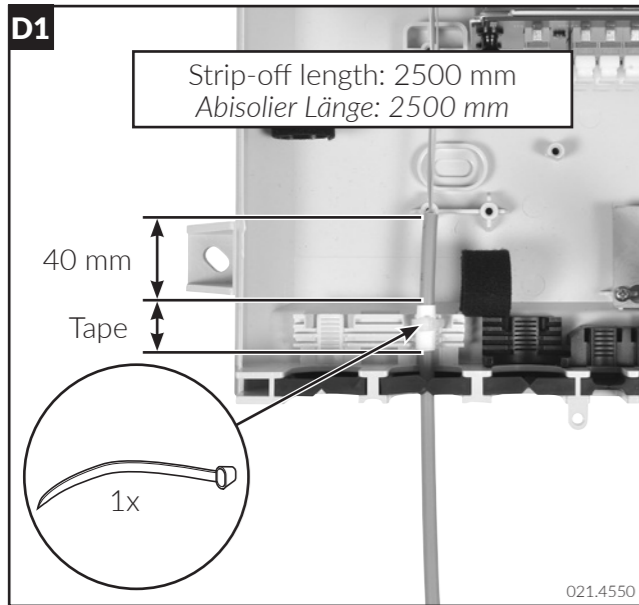

F - Backbone cabling - Pre-terminated cable / Backbone-Verkabelung - vorkonfektionierte Kabel

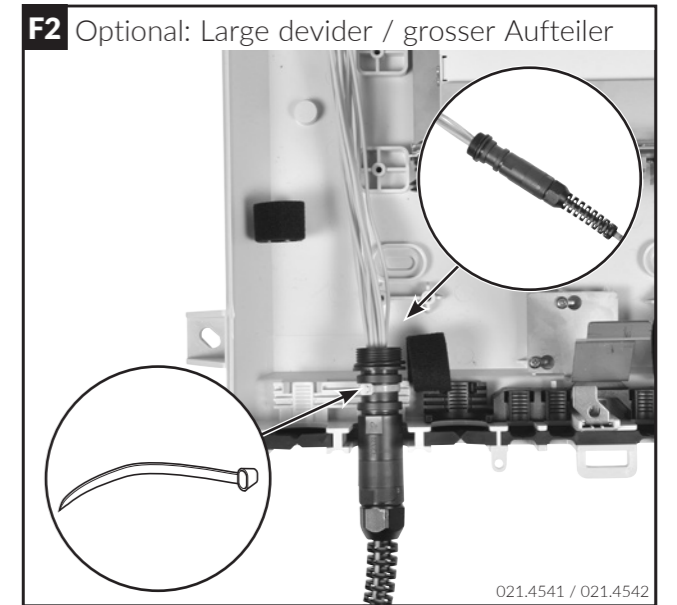
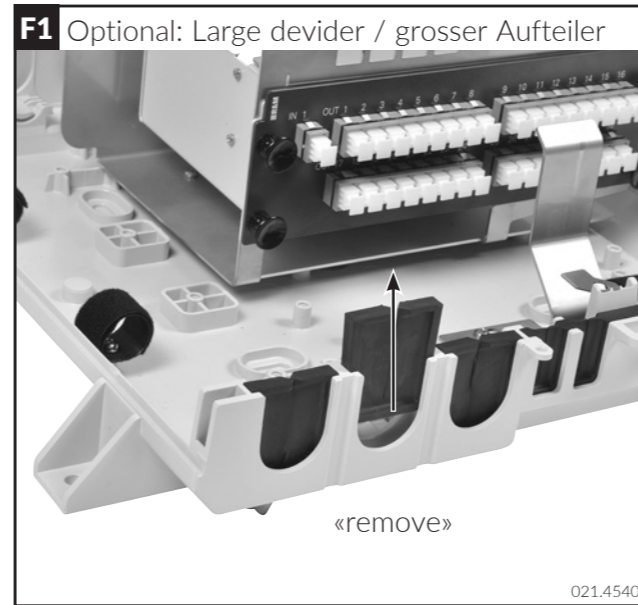

G - Horizontal cabling / Horizontale-Verkabelung

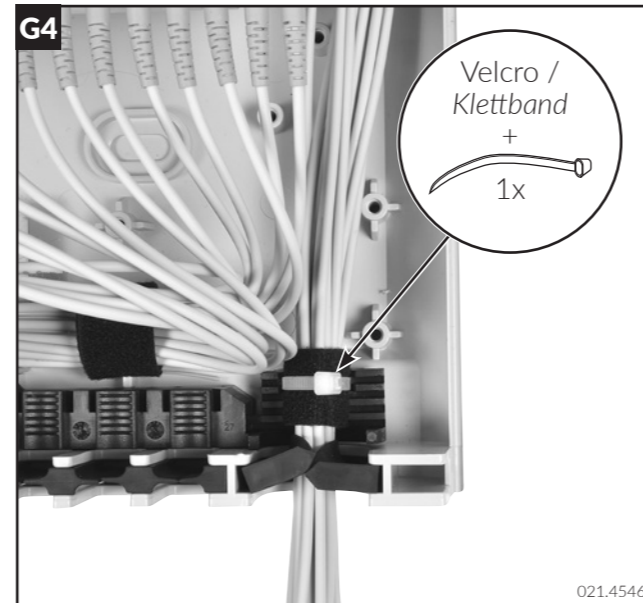
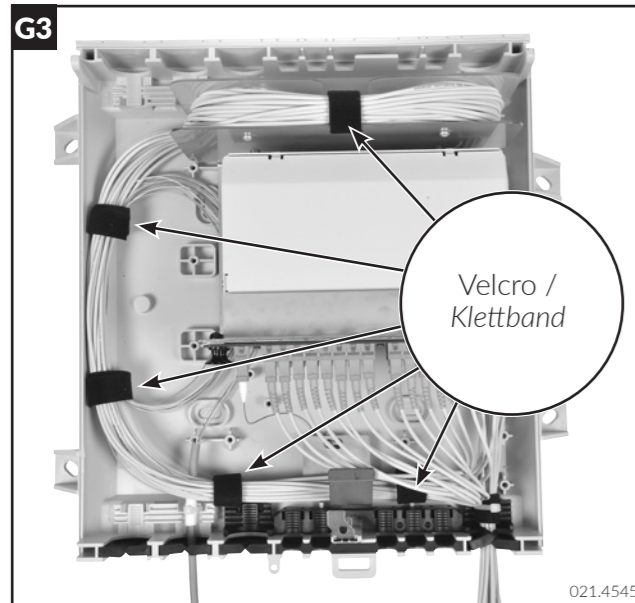
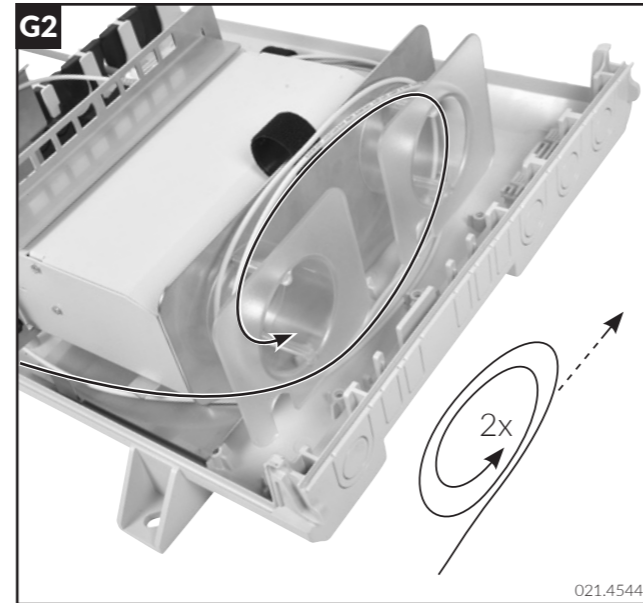
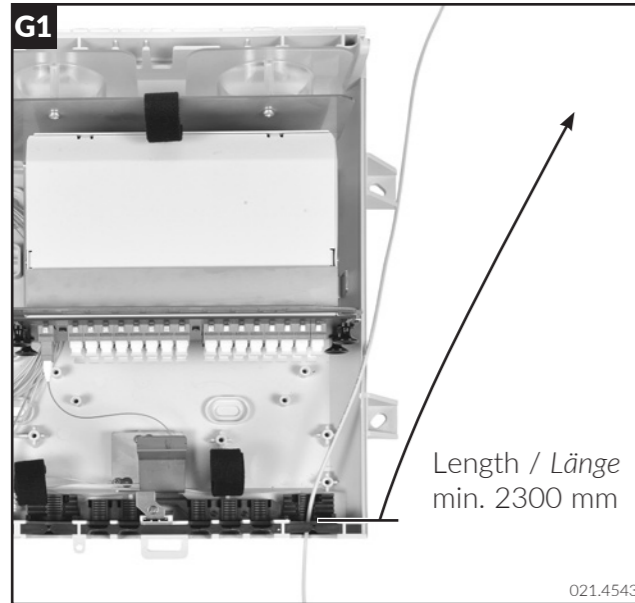

H - Cabling direct port / Verkabelung der direkten Anschlüsse

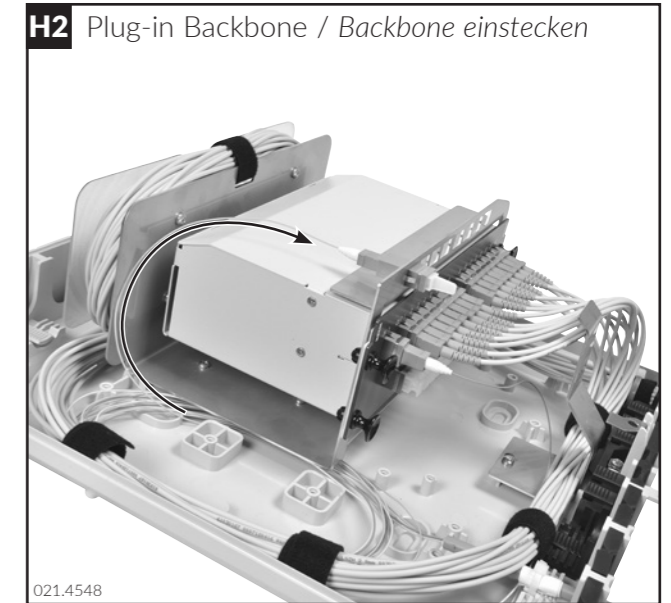
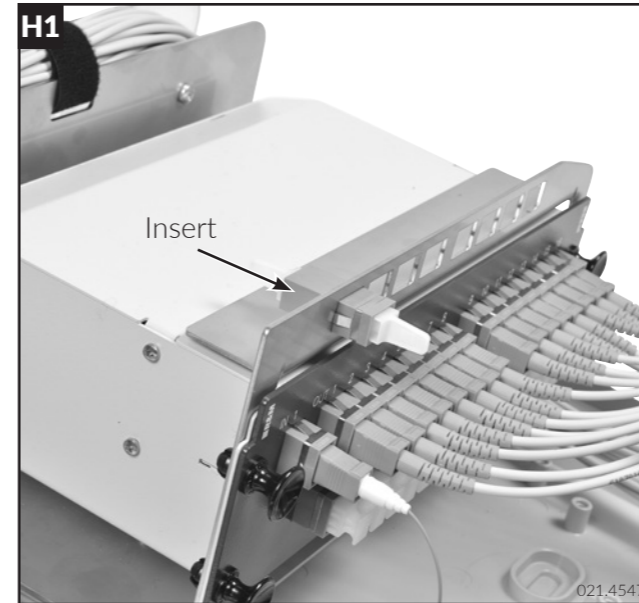

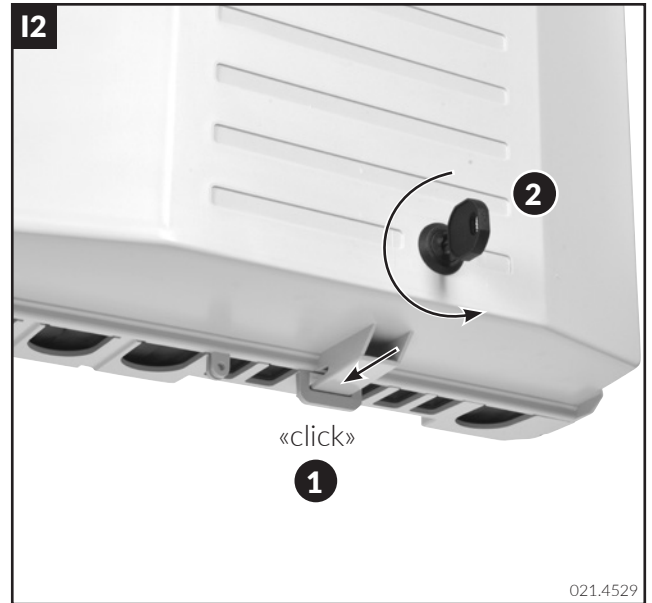
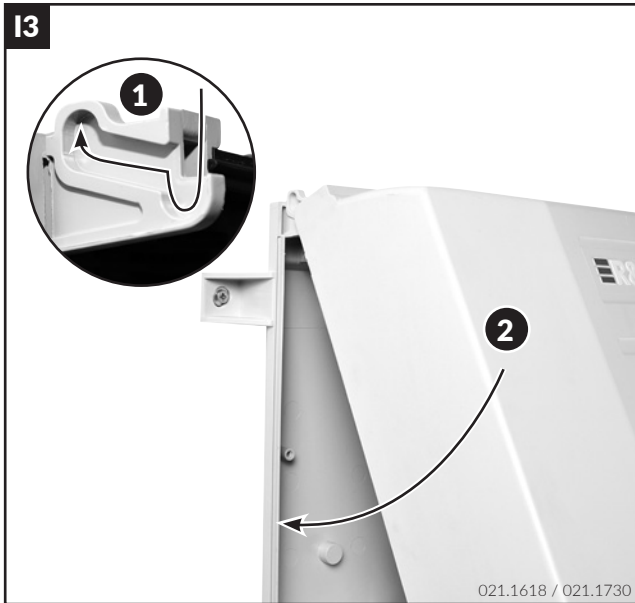

Headquarters

Switzerland

Reichle & De-Massari AG

Binzstrasse 32

CHE-8620 Wetzikon

Telephone HQ +41 (0)44 933 81 11

Telefax HQ +41 (0)44 930 49 41

E-Mail hq@rdm.com

www.rdm.com

R&M